



LED Lighting Catalog 2014

Huakia Optoelectronic Technologies Co., Ltd.
Address: Building C, No.6 Tangwei Industrial Avenue, Fuyong Street,
Baoan, District, Shenzhen, China.
Tel: +86 755 26402393 Fax: +86 755 26405204
Email: sales@huakia.com
Http://www.huakia.com



MENU

- LED Bulb.....3
- Candle LED.....3
- LED Tube.....4
- LED Spotlight.....5
- Why Huakia Spotlight.....6
- LED Downlight.....7
- LED Panel Light.....8
- LED Strip.....9
- LED Plug Light.....10
- LED Fixtures.....11
- LED Floodlight.....12
- LED High Bay Light.....13
- LED Street Light.....14
- LED XPower Light
 - Spotlight..... 15
 - Bulb..... 15
 - Patio Light..... 16
 - Track Light..... 16
- You may also like.....17
- Made With Huakia..... 18

About Huakia

HUAKIA optoelectronic, professional in the application of LED Components, High Power LED and LED Lighting products development, design, production and sales, services for the integration, it is a technology-based enterprises. With the advantages of development, manufacturing in Shenzhen city, Chinese mainland. We holding the conception of “cooperation, trust, persistence innovation” and attitude on products quality improvement are to become internationally renowned LED devices and integrated LED application products manufacturers, service for the global LED demander.

HUAKIA optoelectronic upholding "Beyond Led" for its mission, to improve the quality as its attitude, the development and world-class service, you could be received the most appropriate products and service here. The selection of raw materials, components production, debugging applications, installation, the whole integrity of the scientific process and the producing control process are to ensure a solid basis for product quality.

Our factory strictly enforced internal 5S management standard, and have passed the ISO9001:2001 quality system certification. The technology research team adopt advanced circuit design software, optical simulation software, high-quality sales team and improve the service system to ensure that our products to be the most stable and cost-effective in the global synchronization.



LED Bulb



Bulb Power	3W	5W	8W	10W
Lumens	270lm	450lm	700lm	880lm
Cap-Base	E26,E27			
Color	Warm White(2700-3300k), Nature White(4000-5000K), Cold White(5500-6500K)			
Wattage Equivalent	25W	40W	60W	80W
Dimmable	Availabe			
Input Voltage	AC85-245V,50~60Hz			
Rated Lifetime	30000hours			

LED Tube



Tube Length	600mm	900mm	1200mm
Wattage	7W	10W	13W
Lumens	650lm	900lm	1200lm
Color	Warm White(2700-3300k), Nature White(4000-5000K), Cold White(5500-6500K)		
Cap-Base	G5		
Dimmable	Availabe		
Input Voltage	AC85-245V,50~60Hz		
Rated Lifetime	30000hours		

Candle LED



Bulb Power	4W	4W	4W	3W
Lumens	400lm	400lm	400lm	300lm
Cap-Base	JDRE14,E12,E14			
Color	Warm White(2700-3300k), Nature White(4000-5000K), Cold White(5500-6500K)			
Wattage Equivalent	25W	30W	30W	30W
Dimmable	Availabe			
Input Voltage	AC85-245V,50~60Hz			
Rated Lifetime	30000hours			

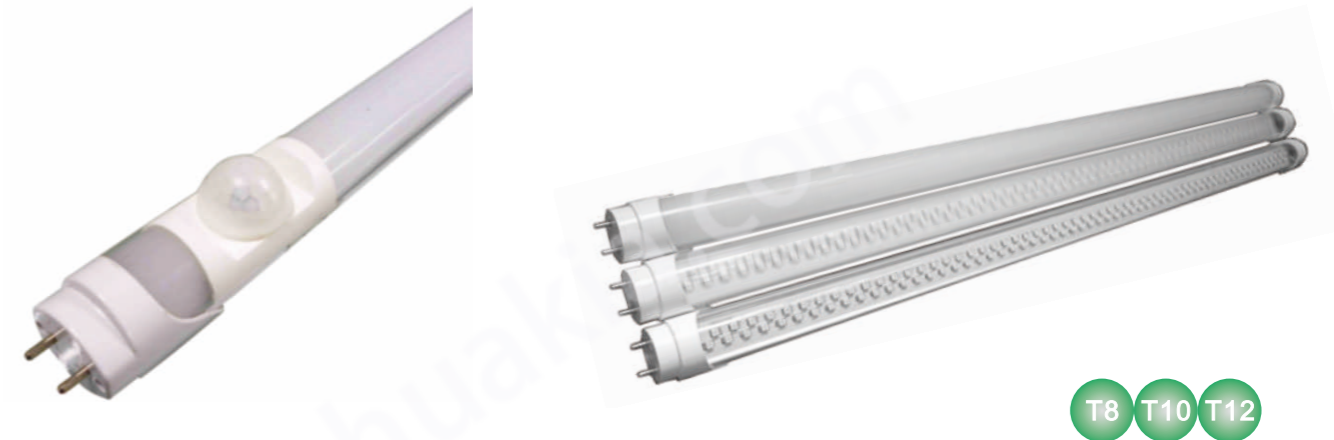

Tube Length	600mm	900mm	1200mm	1500mm	2400mm
Wattage	10W	12W	18W	24W	32W
Lumens	800lm	1200lm	1600lm	2100lm	3200mm
Color	Warm White(2700-3300k), Nature White(4000-5000K), Cold White(5500-6500K)				
Cap-Base	G13				
Dimmable	Availabe				
Input Voltage	AC85-245V,50~60Hz				
Rated Lifetime	30000hours				



LED Spotlight



Bulb Power	4W	5W	7W	9W
Lumens	300lm	400lm	600lm	800lm
Cap-Base	MR16, GU10, GU5.3, E26, E27			
Color	Warm White(2700-3300k), Nature White(4000-5000K), Cold White(5500-6500K)			
Dimmable	Availabe			
Input Voltage	AC85-245V,50~60Hz			
Rated Lifetime	40000hours			

LED Spotlight



Bulb Power	4W	8W	12W	35W
Lumens	280lm	560lm	850lm	35000lm
Cap-Base	MR16, GU10, GU5.3, E26, E27			
Color	Warm White(2700-3300k), Nature White(4000-5000K), Cold White(5500-6500K)			
Dimmable	Availabe			
Input Voltage	AC85-245V,50~60Hz			
Rated Lifetime	30000hours			

5

6



Bulb Power	7W	12W	12W	12W
Lumens	700lm	1200lm	1200lm	1200lm
Cap-Base	GU10, E26, E27, AR111			
Color	Warm White(2700-3300k), Nature White(4000-5000K), Cold White(5500-6500K)			
Dimmable	Availabe			
Input Voltage	AC85-245V,50~60Hz			
Rated Lifetime	40000hours			

Why Huakia Spotlight



LED Downlight



Bulb Power	1W	3W	5W
Lumens	100lm	300lm	500lm
LED	1x1W	3x1W	5x1W
Color	Warm White(2700-3300k), Nature White(4000-5000K), Cold White(5500-6500K)		
Dimmable	Availabe		
Input Voltage	AC85-245V,50~60Hz,External Power Supply		
Rated Lifetime	30000hours		

LED Panel Light



NEW **44W** **4000 Lumen** **40000 Hours**

Features

- A unique and elegant appearance and fashion angel wings, and from LV design concept.
- Using Mitsubishi LGP. Taiwan High lumen LED light source, a unique optical design.
- Its frame is made of anodized aluminum, black and silver two versions, more fashion and art.
- Widely used in home and office lighting, mall lighting, windows and lighting. Plate lighting and art lighting, backlighting.
- There is no darkness, no bright side, the lighting is soft, uniform, instant start, no flicker, no harm.
- Stable and lasting life is more than 30,000 hours, 50 times than incandescent lamps, it is 10 times more energy-saving lamps.

Size

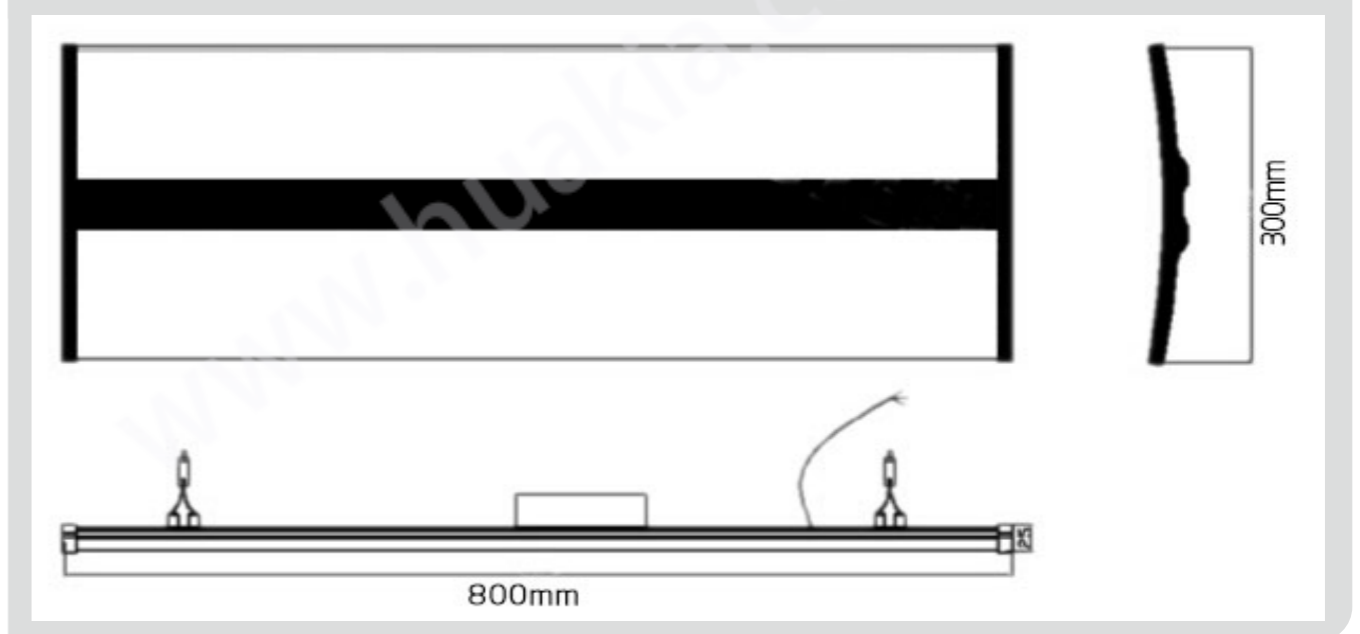

Bulb Power	9W	15W	3W
Lumens	900lm	1500lm	300lm
LED	9x1W	15x1W	3x1W
Color	Warm White(2700-3300k), Nature White(4000-5000K), Cold White(5500-6500K)		
Dimmable	Availabe		
Input Voltage	AC85-245V,50~60Hz,External Power Supply		
Rated Lifetime	30000hours		



LED Strip



LED Quantity	30PCS/Meter		60PCS/Meter		120PCS/Meter		240PCS/Meter	
LED Type	SMD3014	SMD3020	SMD3528	SMD5050	SMD5630	SMD5730		
Emitting Color	Warm White	Nature White	Cold White	Red	Green	Blue	Yellow	R/G/B 3in1
Package	Bare PCB		Tube	Drop Silicon		Inject Silicon in Tube		
PCB Color	White		Yellow		Black			
Dimmable	Availabe							
Input Voltage	DC12V,DC24V							
Rated Lifetime	30000hours							

LED Plug Light



5W	9W
500lm	900lm
11W	13W
1100lm	1300lm
E27, G24	Clear/White Cover

6W	8W
600lm	800lm
10W	12W
1000lm	1200lm
E27, G24, G23	Clear/White Cover

12W	15W
1200lm	1500lm
18W	22W
1800lm	2200lm
2G11	Clear/White Cover

22W	Rotate 180°
2200lm	Dimmable
E40	Clear Cover



LED High Bay Light



300W



100W



200W

Floodlight Power	50W	80W	100W	150W	200W	300W
Lumens	5000lm	8000lm	10000lm	15000lm	20000lm	30000lm
LED	COB High Brightness LED					
Color	Warm White(2700-3300k), Nature White(4000-5000K), Cold White(5500-6500K)					
Input Voltage	AC85-245V,50~60Hz,IP65 Power Supply					
Rated Lifetime	30000hours					

LED Streetlight



180W

Street Light Power	30W	60W	90W	120W	150W	180W
Lumens	3600lm	7200lm	10000lm	13000lm	17000lm	21000lm
LED	CREE Xlamp					
Color	Warm White(2700-3300k), Nature White(4000-5000K), Cold White(5500-6500K)					
Input Voltage	AC85-245V,50~60Hz,MEANWELL IP65 Power Supply					
Rated Lifetime	50000hours					



210W

Street Light Power	60W	90W	120W	150W	180W	210W
Lumens	7200lm	10000lm	13000lm	17000lm	21000lm	25000lm
LED	CREE Xlamp					
Color	Warm White(2700-3300k), Nature White(4000-5000K), Cold White(5500-6500K)					
Input Voltage	AC85-245V,50~60Hz,MEANWELL IP65 Power Supply					
Rated Lifetime	50000hours					



LED Fixtures



- Efficient cooling
- Light weight
- Easy to install
- Professional design
- Adjustable angle
- IP65
- Reflective rate 92%
- Copper heat pipe

Fixtures Power	100W	120W	150W	200W	300W	400W	500W
Lumens	11000lm	13000lm	16000lm	22000lm	33000lm	44000lm	55000lm
LED	CREE XLamp						
Color	Warm White(2700-3300k), Nature White(4000-5000K), Cold White(5500-6500K)						
Input Voltage	AC85-245V,50~60Hz,MEANWELL IP65 Power Supply						
Rated Lifetime	50000hours						

LED Floodlight



Eco Floodlight Power	10W	30W	50W	70W	80W	100W	150W
Lumens	900lm	3000lm	5000lm	7000lm	8000lm	10000lm	15000lm
LED	COB High Brightness LED						
Color	Warm White(2700-3300k), Nature White(4000-5000K), Cold White(5500-6500K)						
Input Voltage	AC85-245V,50~60Hz,WaterProof IP65 Power Supply						
Rated Lifetime	30000hours						



Luxury FloodPower	10W	30W	50W	70W	100W	150W	200W
Lumens	1000lm	3000lm	5000lm	7000lm	10000lm	15000lm	20000lm
LED	COB High Brightness LED						
Color	Warm White(2700-3300k), Nature White(4000-5000K), Cold White(5500-6500K)						
Input Voltage	AC85-245V,50~60Hz,MEANWELL IP65 Power Supply						
Rated Lifetime	50000hours						



LED XPower SpotLight



60W

PAR64	PAR56
60W	36W
6000lm	3600lm
Dim204 x H228mm	Dim173 x H209mm
Warm White, Nature White, Cold White	
AC85-245V,50~60Hz	
50000hours	

15

LED Xpower Patio Light



240W

240W	120W
20000lm	12000lm
Dim350 x H415mm	Dim250 x H299mm
Warm White, Nature White, Cold White	
AC85-245V,50~60Hz	
50000hours	

16

LED XPower Bulb

15W	27W
1200lm	2000lm
Dim100x148mm	Dim130x194mm
36W	50W
2800lm	4000lm
Dim173xH249mm	Dim173xH249mm
60W	120W
4800lm	9600lm
Dim204xH278mm	Dim250xH336mm



120W

LED XPower Track Light



Track Light Series	XL-CIB				XL-PAR		XL-30WS	XL-30WC
Power	30W	7W	60W	12W	30W	60W	30W	30W
Spotlight	Par30	Par30	Par38	Par38	Par30	Par38	/	/
Lumens	3000lm	700lm	6000lm	1200lm	3000lm	6000lm	3000lm	3000lm
LED	Xlamp	Normal	Xlamp	Normal	Xlamp	Xlamp	COB	COB
Color	Warm White(2700-3300k), Nature White(4000-5000K), Cold White(5500-6500K)							
Input Voltage	AC85-245V,50~60Hz							
Rated Lifetime	50000hours							



You may also like

Remote Bulb



Ring Light



Wifi Controller



U-shaped Tube

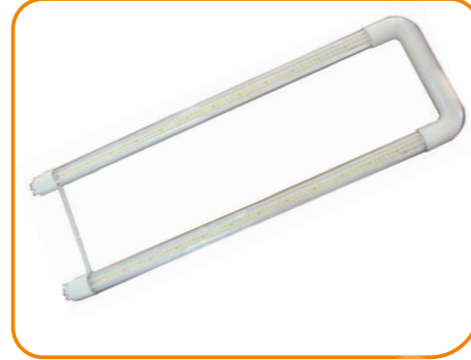

RGB Spotlight



IP65 Strip



RGB Spotlight



IP65 Panel



Made With Huakia

We deep know that under such a period with rapid development in the LED industry today, it is not possible to completely satisfied with all your requirements across the world. HUAKIA in the manufacture conception of "Made with Huakia", it is hoped that to resolve product design or the customers concerned on manufacturing process over the future of manufacturing products to meet the design requirements.

1. Welding LED substrate



2. Product design



3. Optical properties of the design

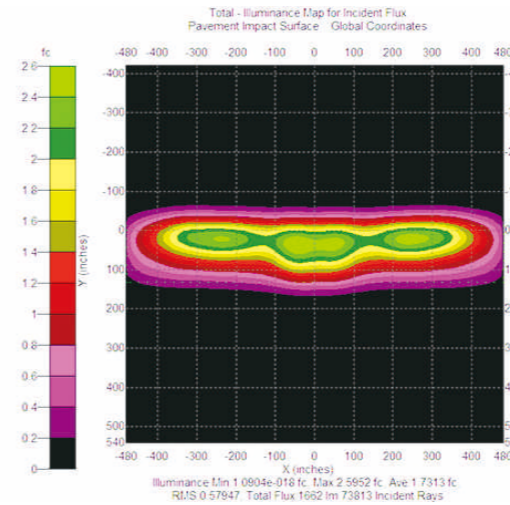

4. Thermal design

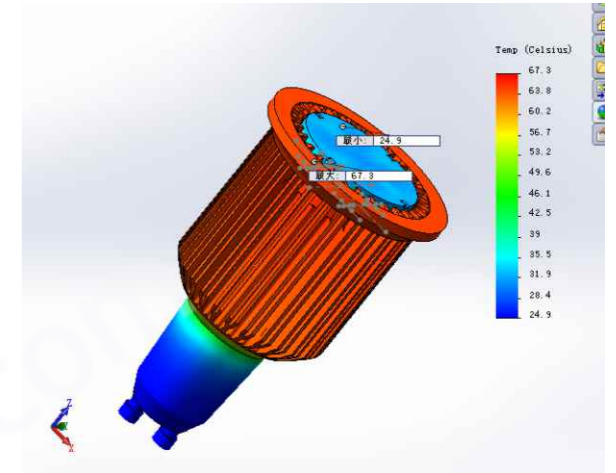

5. Outdoor night landscaping project design and services



Made With HUAKIA

Contact us: tech@huakia.com

